

Installation Guide (Mounting the fixture)

There are a few means of mounting such as Brackets, Magnets, Double sided tapes.
 Follow the guide according to the intended option.

Option 1. Brackets

Fasten HA bracket (AL profile) on surface or recessed position with screws. Screw holes are prepared for fastening.

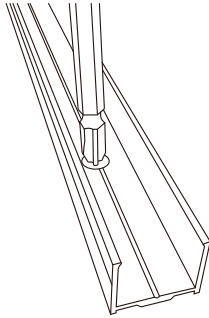

Note 1 : Use suitable screw type depending on the surface material. Recommended base material is metal plate or wood. Materials such as stone, bricks, concrete or drywall need special attention on selection of screw and prior preparation. In case screw is prepared by user, make sure screw head is suitable not to push the fixture.

- Slide in the fixture into HA bracket or push and click in from top.

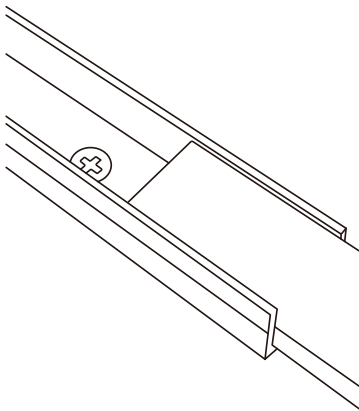

[Slide in]

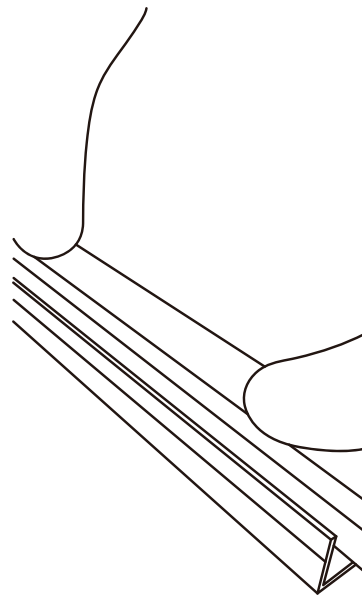

[Push in]

Option 2 . Magnets

Steel or SUS4xx is required as base surface for mounting. The surface of base metal must be flat and must provide sufficient contact area for secure fastening with magnets on the fixtures.
 (Base metal can be sold separately on request. Contact us for more detail.)

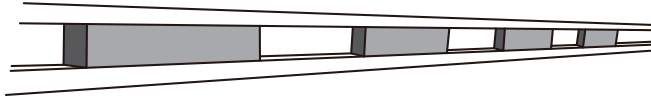

Magnet force is strong. Keep the linear fixture flat and straight while mounting on the base metal by letting the whole fixture contact the base at the same time. (While dismantling from base metal, also maintain the fixture flat and straight holding by both hands) Otherwise, the light bar fixture can be sharply bent that can lead to failure or damage.



Be aware this magnet option is generating strong magnet force/field and avoid this option where it can be fatal to human health or apparatus (e.g., MRI , Compass).

Option 3. Double sided adhesive tape

Clean surface (to remove dirt or oil) should be prepared before attachment. Tapes are pressure sensitive. Firm application pressure is required for better bond strength at min 50°F (10°C) or higher. Porous, rough surface is required to be treated to turn to flat , unified surface before attachment.

Note : The tape adhesion force is very strong once attached. Once attached, removal-attempt can cause sharp bending / damage on the both rigid (e.g MPB series and other light bars)

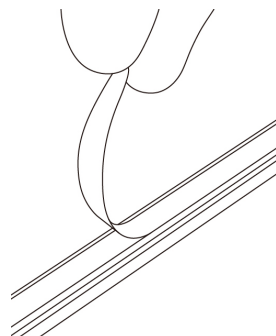

* Data is subject to change without notice for improvement.
 **All copy rights reserved

Installation Guide (Max runs, Electrical wiring)

Max runs

- Each serial interconnection (runs per DC feed) of LED light(Load) must not exceed specified max serial length or 90% of LED driver capacity. At the same time, total load , including parallel connections, should not exceed 90% of the capacity of LED driver.

Electrical wiring

. LED Driver + MPB series (without dimmer)

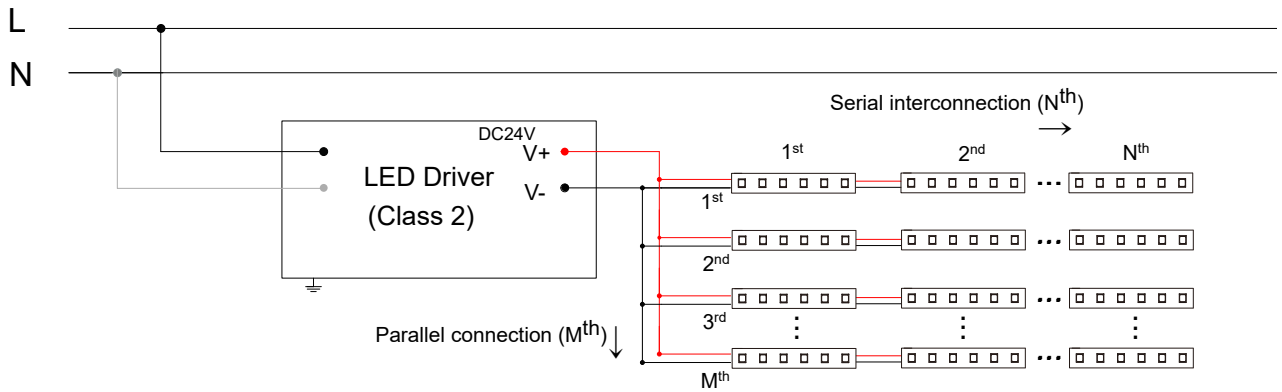

. LED Driver + MPB series (with controller , dual white)

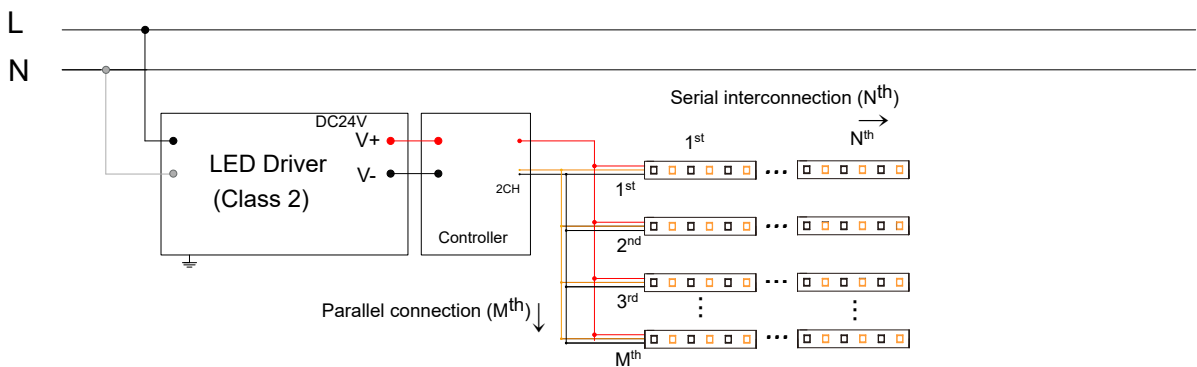

. LED Driver + MPB series (with 0-10 / 1-10 dimmer)

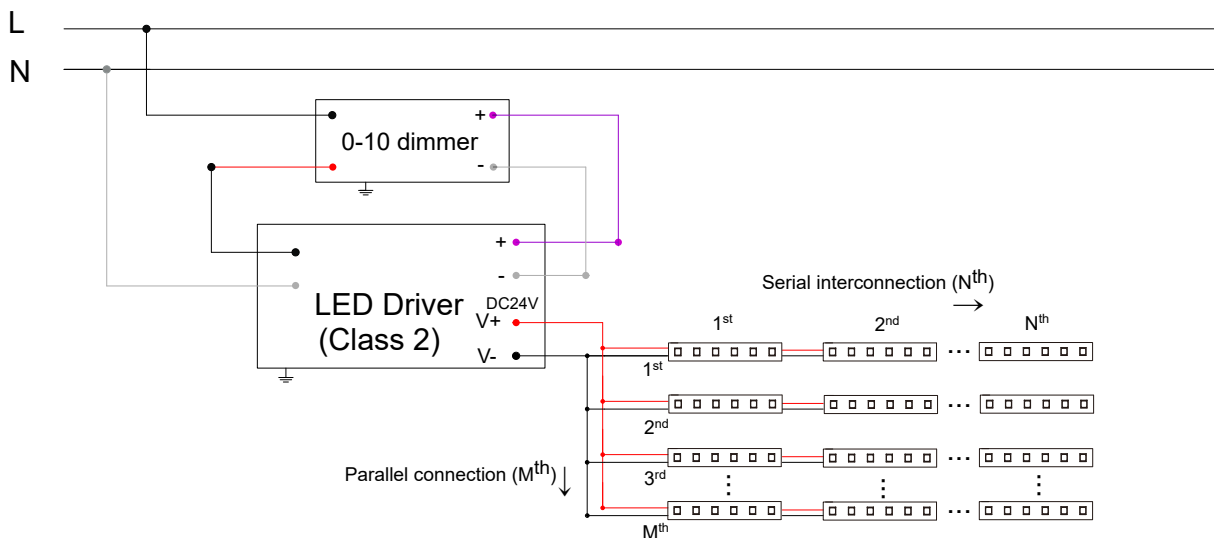

* Data is subject to change without notice for improvement.
 **All copy rights reserved

. LED Driver + MPB series (DMX, RGB)

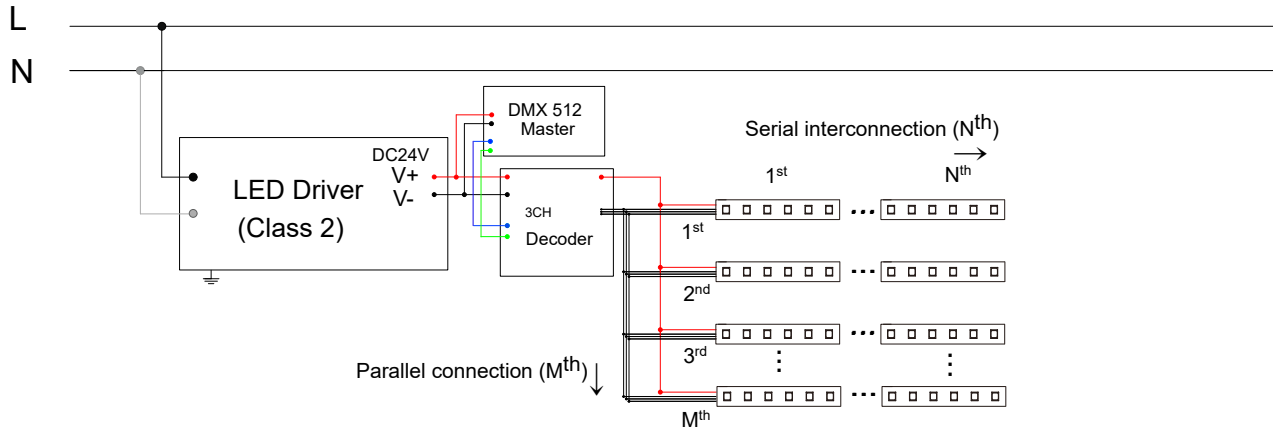

* Data is subject to change without notice for improvement.
 **All copy rights reserved

Precautions

General precautions

- Read carefully and follow precautions, manual and specifications of the product before start of installation of this product. ACROSENTEC will not be held responsible for any defect or damage resulted from inconsistency of this precautions, manual and specifications.
- Installation must be proceeded by qualified personnel and according to rules and local ordinances.
- Handle with care while in transport, store and installation or removal. Excessive physical stress such as impact, bending or warping, compression or vibration can affect the products and cause fatal hazards.

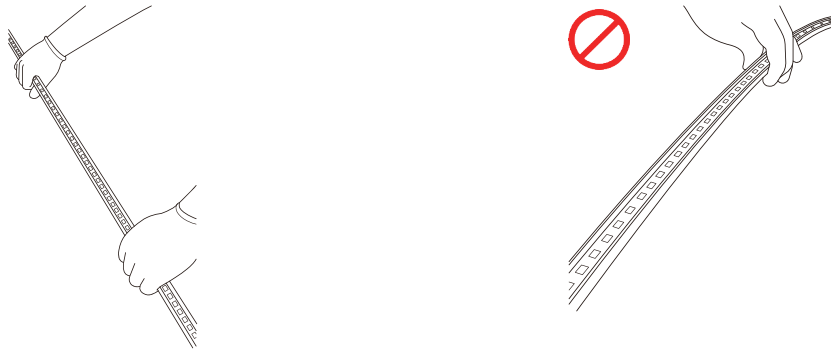

[Note 1 : During installation, holding a long fixture with 2 hands will help prevent them from bending or warping]

- In case of operating the product in constantly or repeatedly **harsh environment**, the product should be customized in production at factory. Harsh environment means a region or a place including but not limited to the space in high temperature or highly humid atmosphere or narrow recessed mounting sites and so on. Please refer to **ABL program** for such customization or bespoke production.

Product inspection

- Examine the product before installation. If any abnormal appearance on the product is observed, do not install and contact ACROSENTEC or an authorized distributor in order to prevent potential risks of malfunctioning and other hazards.
- Be mindful of information printed on product, label or packing.

Check environment and space

- Make sure the product's IP rating is suitable at the operating environment.
- Installation location should be reasonably spacious for heat radiation and air flow / ventilation.
- Completion of installation requires adequate protection against vandalism, insects and animals (and their possible urine).
- UL listing precautions :
 Product for 'Suitable for Damp Locations' mark must not be used wet location.
 Product for 'For cabinet use only' must not be installed in a compartment smaller than 12 " x 12" x the product length(L).

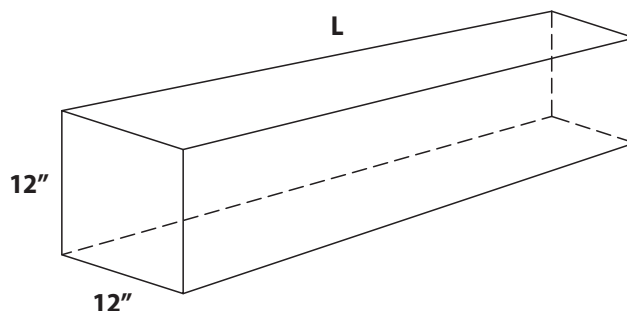

* Data is subject to change without notice for improvement.
 **All copy rights reserved

Electrical, fire hazards



- In order to install safely and operate safely, follow 'Safety and cautions in handling LED driver and wiring' as well as 'Wiring manual , max connections'
- In use of a control gear or a dimmer, consult with ACROSENTEC or an authorized distributor to check compatibility and safety.
- Keep LED driver turned off until installation is completed.
- Wear insulated gloves or take necessary measures to avoid electrical injuries during installation.
- Do not disassemble the product. This may also cause lethal injuries and damages to the property.



* Data is subject to change without notice for improvement.

**All copy rights reserved

Safety and cautions in operation

- Surface of fixture may be hot. Please make sure to avoid skin contact with the operating surface and components.
- For cleaning, use dry or moderately dampened cloth. Do not use solvent.
- Avoid exposure to solvent type paint, similar chemical liquid or aerosol.
- Avoid direct contact with paper, wood and other flammable object or liquid.
- Keep clear of object that interferes with heat radiation and air flow / ventilation.
- Prepare reasonable protection against animals and insect
- Do not use the product in an environment exceeding the specification such as temperature , IP rating, spacing and so on.
- If the product is damaged or abnormal status, immediately discontinue to use.

Safety and cautions in handling LED driver and wiring

- In order to avoid electrical injuries, short circuit or other lethal damage, make sure the LED driver is off before start of wiring the LED load or removal.
- Arrange wire connection from an independent LED driver to LED Modules.
(Do not share output of a different LED driver to the common loads.)

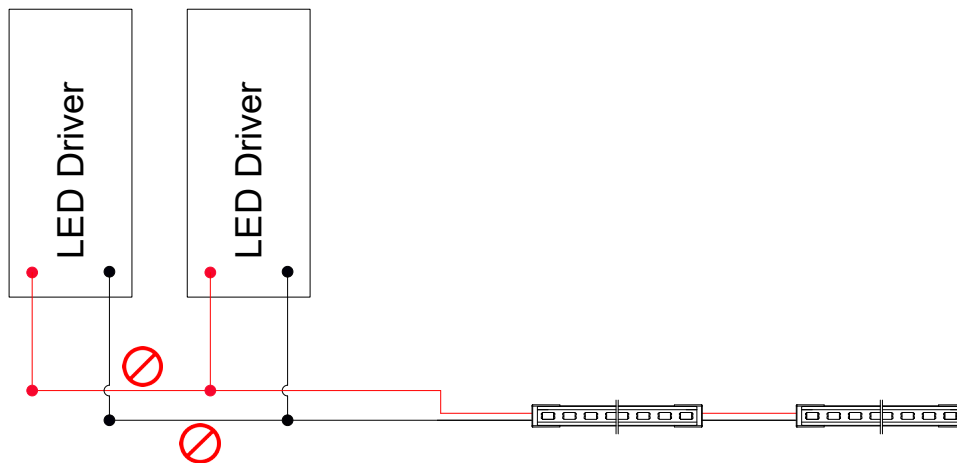

- Make sure to connect output terminal (+, -) correctly to prevent failure of LED or damage of the product, LED driver, and to avoid other potential hazard.
- Special attention is required when interconnecting module to module. If +, - wires are cross-linked at ends or in between, fatal damage can occur on product or LED driver caused from short circuit. This can develop into current and temperature rise and potential fire hazard.

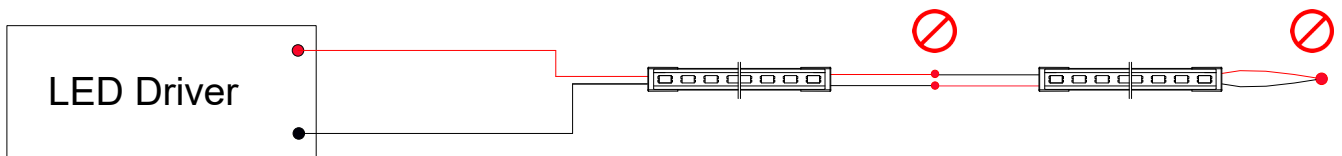

- Loose wire joints or exceeding interconnection of load limit can raise potential hazards.
- In case of using control gear (DMX, 0/1-10 dimmer etc), refer to separate wiring instruction.
- UL listing considerations : Use only with Class 2 power unit.
- Recommended wire capacity vs distance(LW) between LED Driver and Load (LED light) is shown below

	LW [Load up to 96W]	LW [Load up to 80W]	LW [Load up to 50W]	LW [Load up to 30W]
AWG 12	114' 10" / 35 M	114' 10" / 35 M	-	-
AWG 14	74' 1.8" / 22.6 M	95' 1.7" / 29 M	114' 10" / 35 M	-
AWG 16	46' 7.1" / 14.2 M	59' 8.5" / 18.2 M	89' 10.8" / 27.4 M	114' 10" / 35 M
AWG 18	29' 6.4" / 9 M	37' 4.8" / 11.4 M	45' 5.2" / 17.2 M	93' 10" / 28.6 M

@24V output , 68F° / 20C°



* Data is subject to change without notice for improvement.
 **All copy rights reserved