

Installation Guide (Mounting the boards, Wiring on the back)

1. Mounting the boards

There are 2 means of mounting : Double sided tapes or direct screwing. Follow the guide according to the intended option.

Option 1. Double sided adhesive tape

Prepare cable holes on mounting surface and wiring space behind it before mounting.

(Holes on mounting surface are not required for options of wiring on top of boards.)

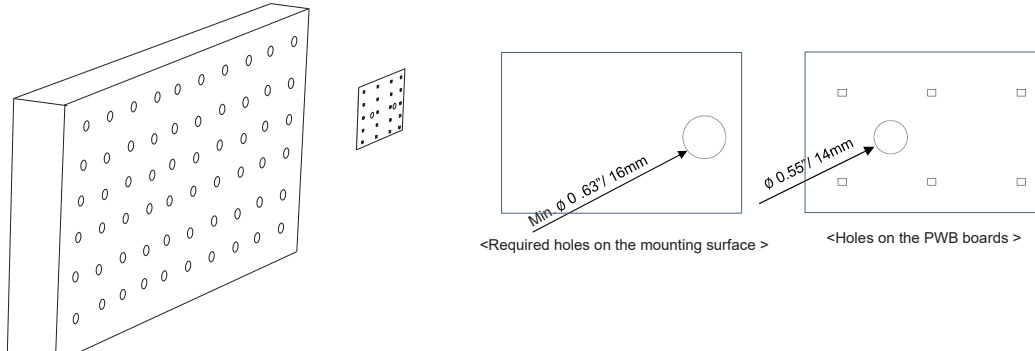

Clean surface (to remove dirt or oil) should be prepared before attachment.

Tapes are pressure sensitive. Firm application pressure is required for better bond strength at min 50°F (10°C) or higher.

Porous, rough surface is also required to be treated to turn to unified surface before attachment.

Attach the product with double sided tape side by side on the area surface depending on light box or fixture design.

Make sure to mount on the accurate positions of holes of boards and mounting surface.

Note1 : LEDs on Matrix board are vulnerable to pressure while attaching. Please make sure not to put direct pressure on LEDs and other electronic components.

Note2 : The tape adhesion force is very strong once attached. Once attached, removal-attempt can cause sharp bending / damage on the MATRiX board. For this reason, do not reuse once removed product or attempted product.



Option 2. Direct screwing

There are screw holes on the boards for screw fastening. Use enclosed plastic washers on screws.

Pay attention not to damage the boards while screwing.

Fasten the product with screw side by side on the area surface depending on light box or fixture design. Make sure to mount on the accurate positions of holes of boards and mounting surface.

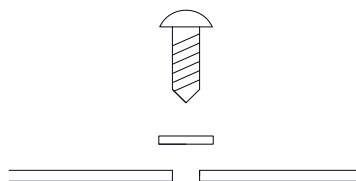

Installation Guide (Mounting the boards, Wiring on the back)

2. Wiring between boards (at the back)

[For **XFC0, **C03 type]

Place the connectors through the holes from back and connect the receptacles between boards.

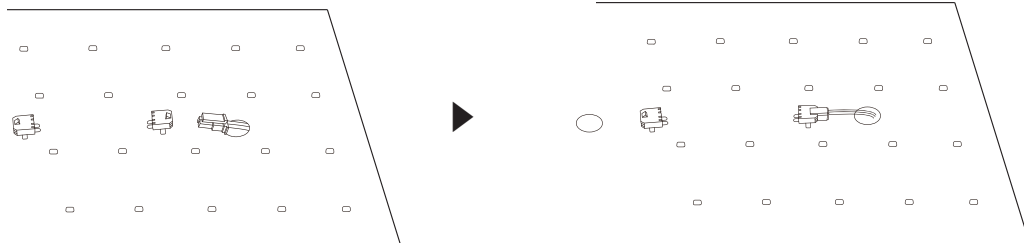

[For **RFMC0 / C3, **WFM4C3 type]

Link the connectors between boards at the back.

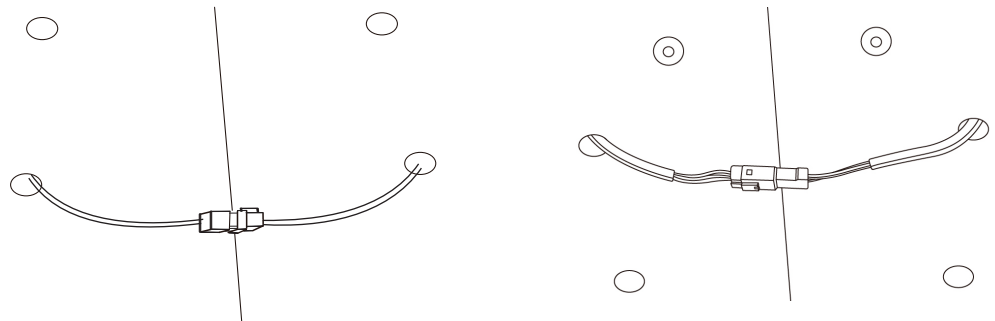

Wiring with PSU, Controls

Connect the PSU, control gear(optional) and power on to test and check.

Power off for next step.

Completing

Apply secondary fastening such as sealant on the edges of boards.

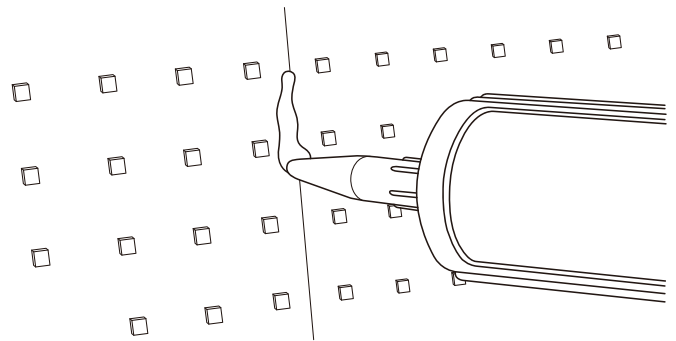

Gently pull the extra (if any) length of cables behind and tie it to keep them behind.

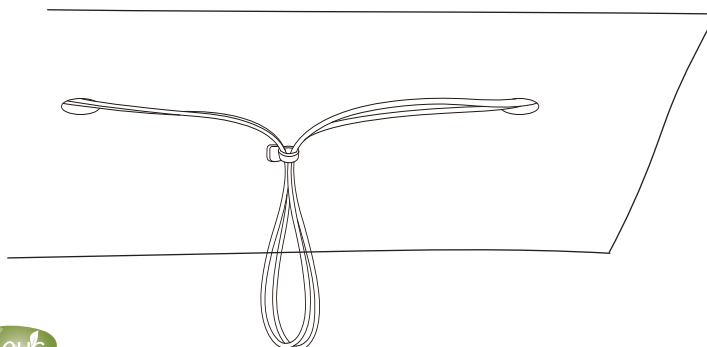

Installation Guide (Mounting the boards, Wiring on top)

1. Mounting the boards

There are 2 means of mounting : Double sided tapes or direct screwing. Follow the guide according to the intended option.

Option 1. Double sided adhesive tape

Clean surface (to remove dirt or oil) should be prepared before attachment.
 Tapes are pressure sensitive. Firm application pressure is required for better bond strength at min 50°F (10°C) or higher.
 Porous, rough surface is also required to be treated to turn to unified surface before attachment.

Attach the product with double sided tape side by side on the area surface depending on light box or fixture design.
 Make sure to mount on the accurate positions of holes of boards and mounting surface.

Note1 : LEDs on Matrix board are vulnerable to pressure while attaching. Please make sure not to put direct pressure on LEDs and other electronic components.

Note2 : The tape adhesion force is very strong once attached. Once attached, removal-attempt can cause sharp bending / damage on the both rigid (e.g MPB series and other light bars) and flexible product. (e.g FPCB, FPB, Flexi LED, F.Matrix board).
 For this reason, do not reuse once removed product or attempted product.

- Note1 -

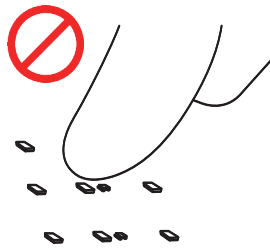

- Note2 -

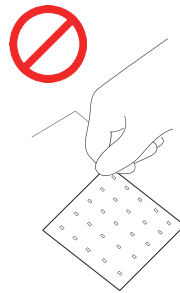

Option 2. Direct screwing

There are screw holes on the boards for screw fastening. Use enclosed plastic washers on screws.
 Pay attention not to damage the boards while screwing.

Fasten the product with screw side by side on the area surface depending on light box or fixture design. Make sure to mount on the accurate positions of holes of boards and mounting surface.

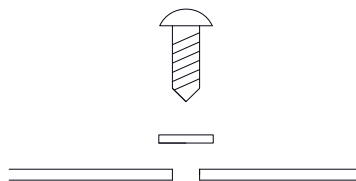

Installation Guide (Mounting the boards, Wiring on top)

2 Wiring between boards (on top side)

[For **XFC0, **C03 type]

Connect the receptacles between boards

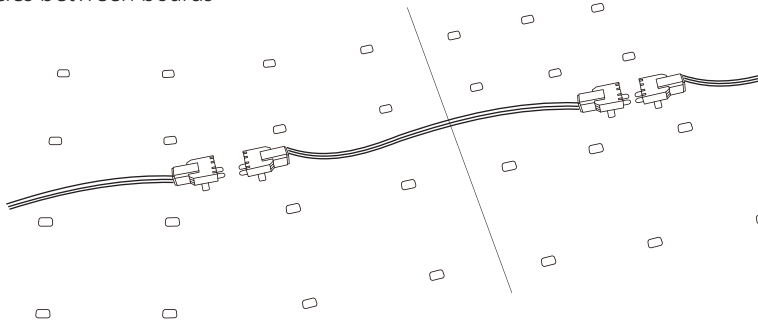

[For **RFMC0 / C3 그림, **WFM4C3 type]

Link the connectors between boards.

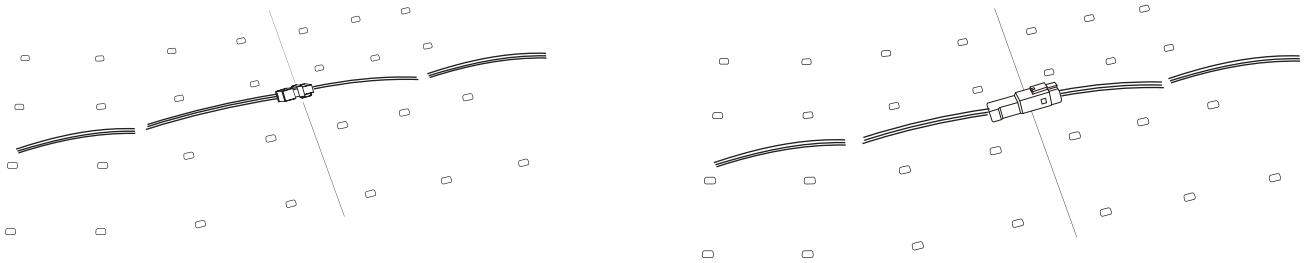

Wiring with PSU, Controls

Connect the PSU, control gear(optional) and power on to test and check.

Power off for next step.

Completing

Apply secondary fastening such as sealant on the edges of boards.

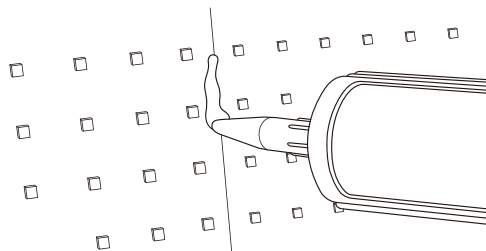

In order to prevent cables from blocking the light, apply sealant on cables to be held in position

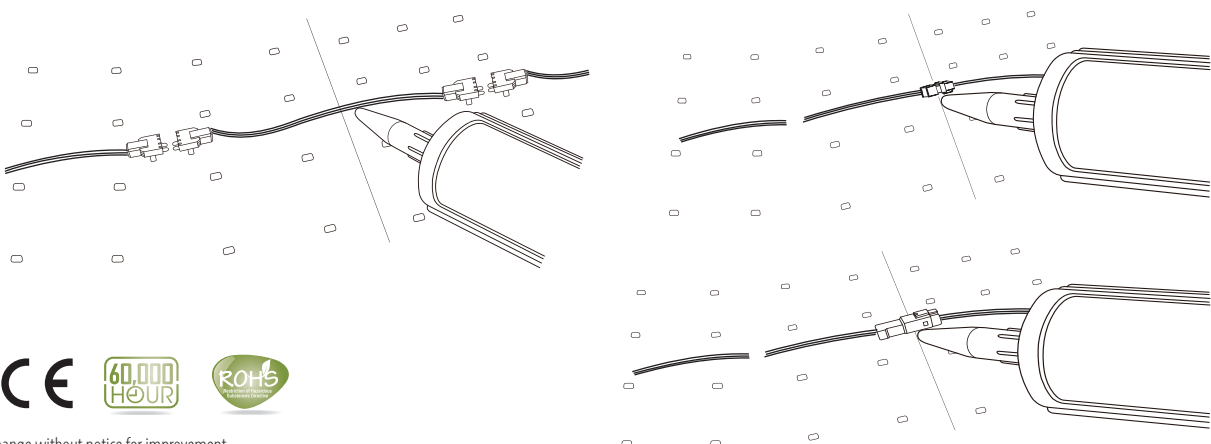

Installation Guide (Max runs, Electrical wiring)

Max runs

- Each serial interconnection (runs per DC feed) of LED light(Load) must not exceed specified max serial length or 90% of LED driver capacity. At the same time, total load , including parallel connections, should not exceed 90% of the capacity of LED driver.

Electrical wiring

. LED Driver + MATRiX BOARD (without dimmer)

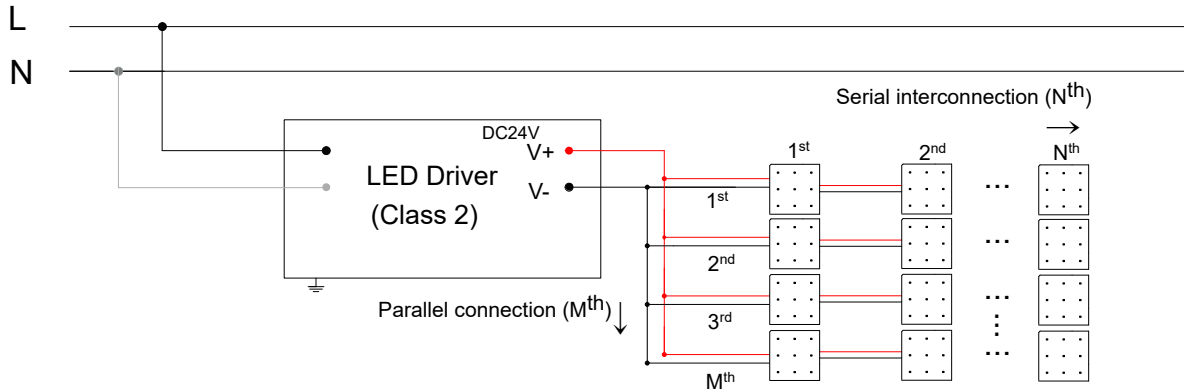

. LED Driver + MATRiX BOARD (with controller , dual white)

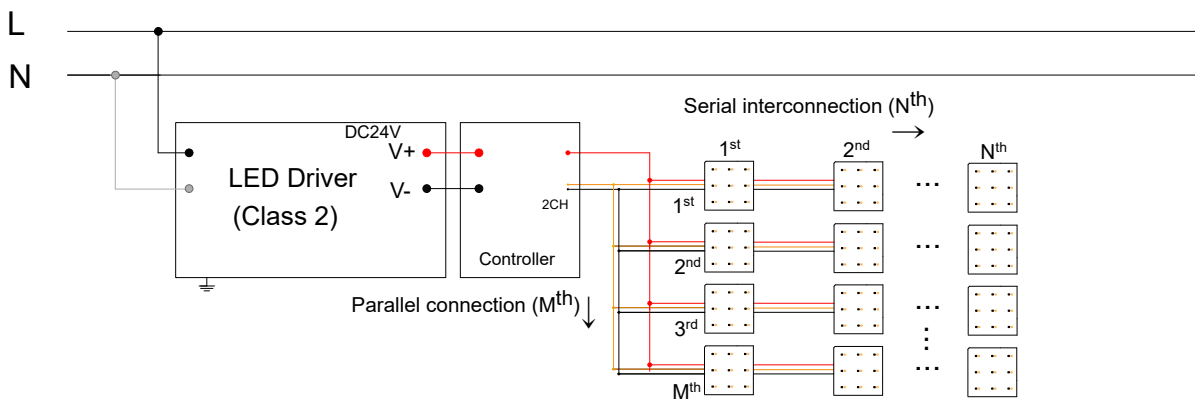

. LED Driver + MATRiX BOARD (with 0-10 / 1-10 dimmer)

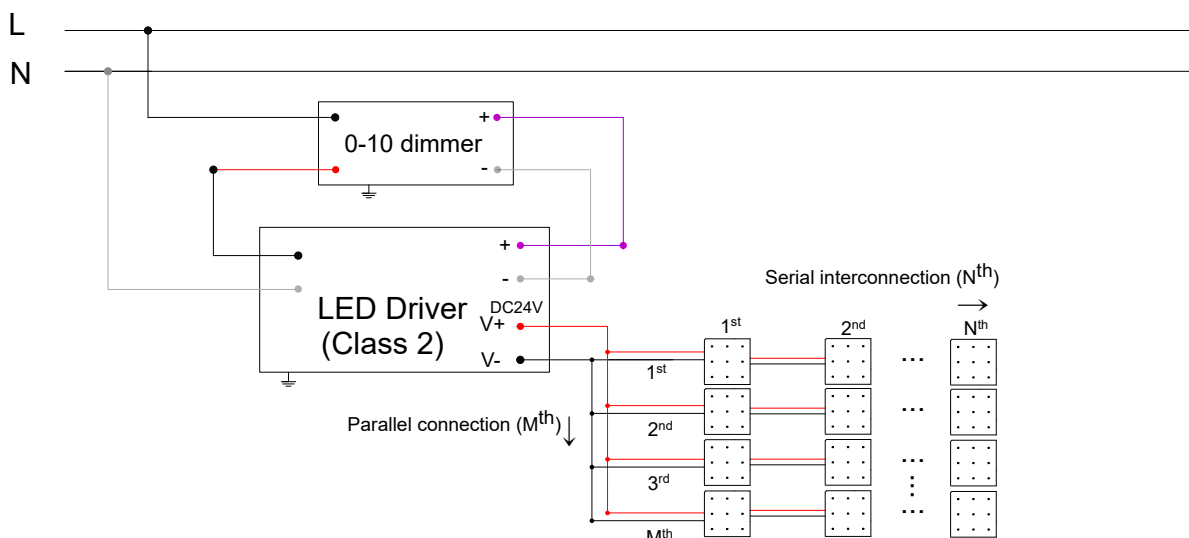

* Data is subject to change without notice for improvement

Precautions

General precautions

- Read carefully and follow precautions, manual and specifications of the product before start of installation of this product. ACROSENTEC will not be held responsible for any defect or damage resulted from inconsistency of this precautions, manual and specifications.
- Installation must be proceeded by qualified personnel and according to rules and local ordinances.
- Handle with care while in transport, store and installation or removal. Excessive physical stress such as impact, bending or warping, pressing or stacking, compression or vibration can affect the products and cause fatal hazards.

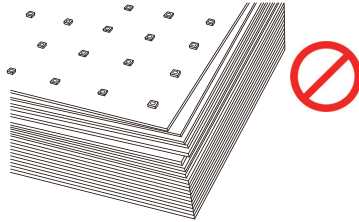

- When handling Flexible product and FPCBs or LED lights without cover protection, do not touch, press or impact, loads on LEDs and components. A sharp tool also can make scratch / cut on circuit pattern and wires, resulting in fatal damage on product or other hazard such as electrical short circuit that can develop into defect and even fire. (송곳 칼)

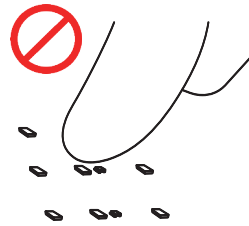

- In case of operating the product in constantly or repeatedly **harsh environment**, the product should be customized in production at factory. Harsh environment means a region or a place including but not limited to the space in high temperature or highly humid atmosphere or narrow recessed mounting sites and so on. Please refer to **ABL program** for such customization or bespoke production.

Product inspection

- Examine the product before installation. If any abnormal appearance on the product is observed, do not install and contact ACROSENTEC or an authorized distributor in order to prevent potential risks of malfunctioning and other hazards.
- Be mindful of information printed on product, label or packing.

Check environment and space

- Make sure the product's IP rating is suitable at the operating environment.
- Installation location should be reasonably spacious for heat radiation and air flow / ventilation.
- Completion of installation requires adequate protection against vandalism, insects and animals (and their possible urine).
- UL listing precautions : Product for 'Suitable for Damp Locations' mark must not be used wet location.



* Data is subject to change without notice for improvement

Electrical, fire hazards



- In order to install safely and operate safely, follow 'Safety and cautions in handling LED driver and wiring' as well as 'Wiring manual , max connections'
- In use of a control gear or a dimmer, consult with ACROSENTEC or an authorized distributor to check compatibility and safety.
- Keep LED driver turned off until installation is completed.
- Wear insulated gloves or take necessary measures to avoid electrical injuries during installation.
- Do not disassemble the product. This may also cause lethal injuries and damages to the property.



* Data is subject to change without notice for improvement

Safety and cautions in operation

- Surface of fixture may be hot. Please make sure to avoid skin contact with the operating surface and components.
- Avoid exposure to solvent type paint, similar chemical liquid or aerosol.
- Avoid direct contact with flammable object or liquid.
- Keep clear of object that interferes with heat radiation and air flow / ventilation.
- Prepare reasonable protection against dust, animals and insect. (Accumulated dust or insects can absorb and contain moisture that can cause short circuit on unprotected circuits of the boards. Periodic removal of such accumulation is recommended.)
- Do not use the product in an environment exceeding the specification such as temperature , IP rating, spacing and so on.
- If the product is damaged or abnormal status, immediately discontinue to use.

Safety and cautions in handling LED driver and wiring

- In order to avoid electrical injuries, short circuit or other lethal damage, make sure the LED driver is off before start of wiring the LED load or removal.
- Arrange wire connection from an single LED driver within a circuitry of LED Modules .
(Do not share output of different LED drivers to the common loads.)

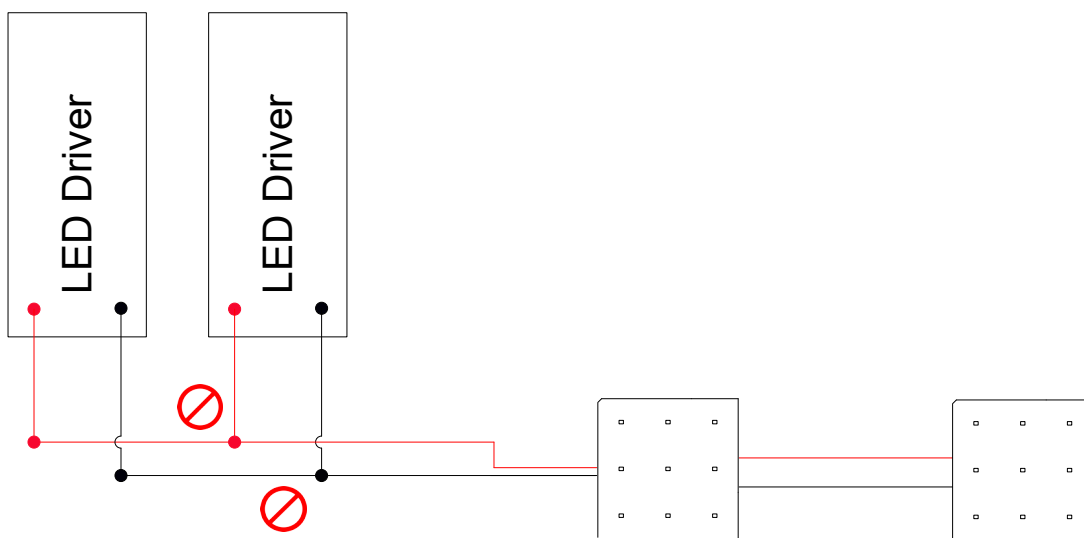

- Make sure to connect output terminal (+, -) correctly to prevent failure of LED or damage of the product, LED driver, and to avoid other potential hazard.
- Special attention is required when interconnecting module to module. If +, - wires are cross-linked at ends or in between, fatal damage can occur on product or LED driver caused from short circuit. This can develop into current and temperature rise and potential fire hazard.

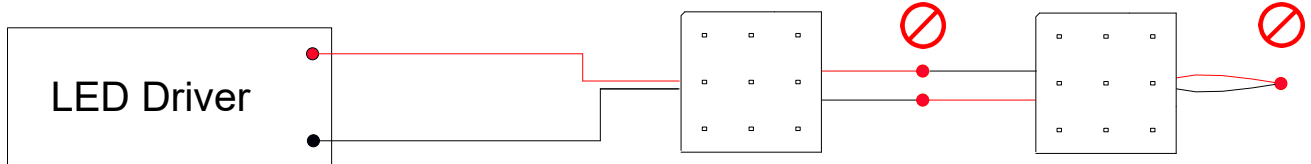

- Loose wire joints or exceeding interconnection of load limit can raise potential hazards.
- In case of using control gear (DMX, 0/1-10 dimmer etc), refer to separate wiring instruction.
- UL listing considerations : Use only with Class 2 power unit.
- Recommended wire capacity vs distance(LW) between LED Driver and Load (LED light) is shown below

	LW [Load up to 96W]	LW [Load up to 80W]	LW [Load up to 50W]	LW [Load up to 30W]
AWG 12	114' 10" / 35 M	114' 10" / 35 M	-	-
AWG 14	74' 1.8" / 22.6 M	95' 1.7" / 29 M	114' 10" / 35 M	-
AWG 16	46' 7.1" / 14.2 M	59' 8.5" / 18.2 M	89' 10.8" / 27.4 M	114' 10" / 35 M
AWG 18	29' 6.4" / 9 M	37' 4.8" / 11.4 M	45' 5.2" / 17.2 M	93' 10" / 28.6 M

@24V output , 68F° / 20C°